

# Ergo Glass with Rotation

Lifting Capacity: 80/150/240kg

The Ergo Glass™ end effector that, when integrated in Quick-Lift System™, meets the highest standards of ergonomics, working environment, safety and efficiency.

Easy to use, thanks to outstanding responsiveness, regardless of load weight. High cost efficiency through built in energy save function, high reliability and long durability.

The sensitive manoeuvre handle provides the operator a precise and controlled movement of the glass panel.

Equipped with a stepless rotation of the suction cups as well as a pneumatic changeable center of gravity point. Available with either manual or pneumatic controlled rotation.

Modular design of the vacuum suction interface creates unlimited possibilities for customized solutions.

The position of the suction cups can be configured according to the dimensions of the glass panel.

Maximum security due to a combination of sound and visual alarms activated in case of pressure drop or lack of vacuum.

With integrated “anti-drop” and energy saving as standard this end effector provides a first class solution.

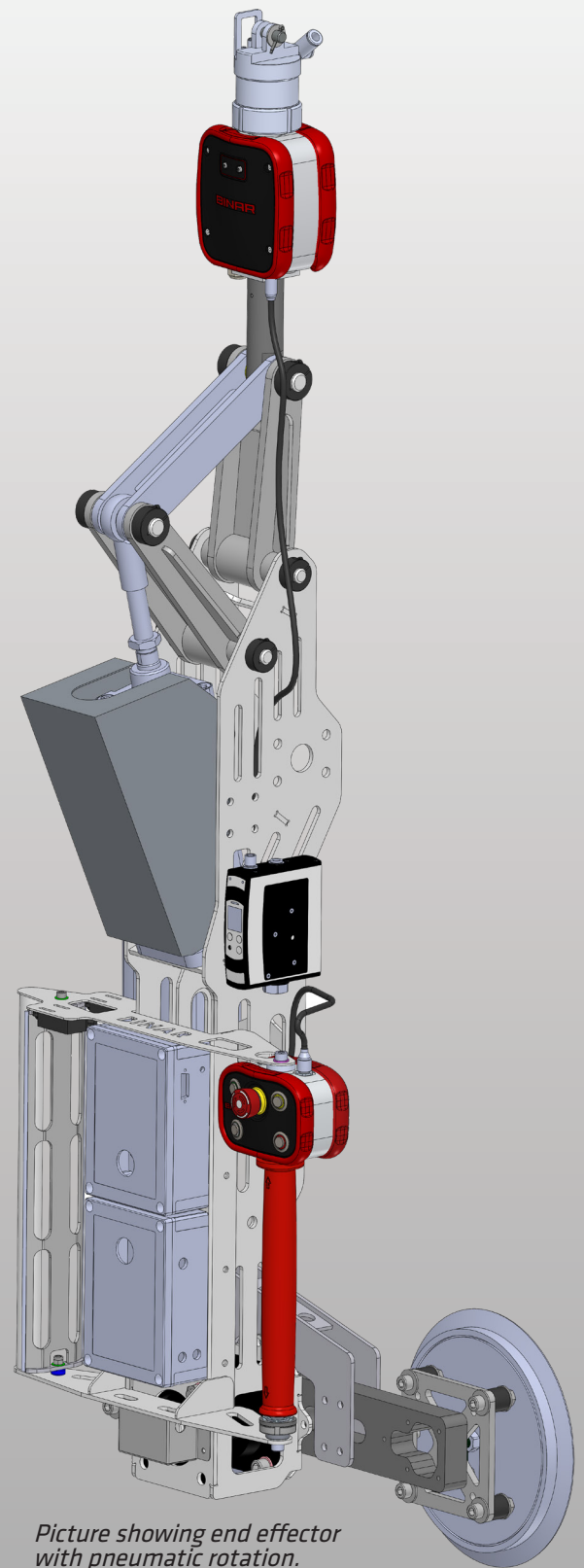

*Picture showing end effector with pneumatic rotation.*

# Ergo Glass with Rotation

(EGR)

Lifting Capacity: 80/150/240kg

The figures are to be seen as indications and may vary depending on handling application.

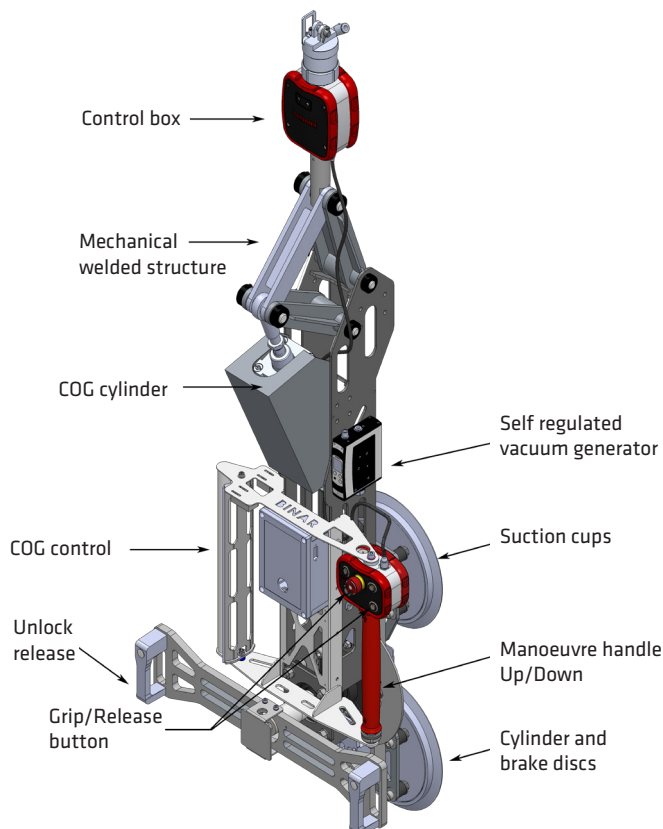
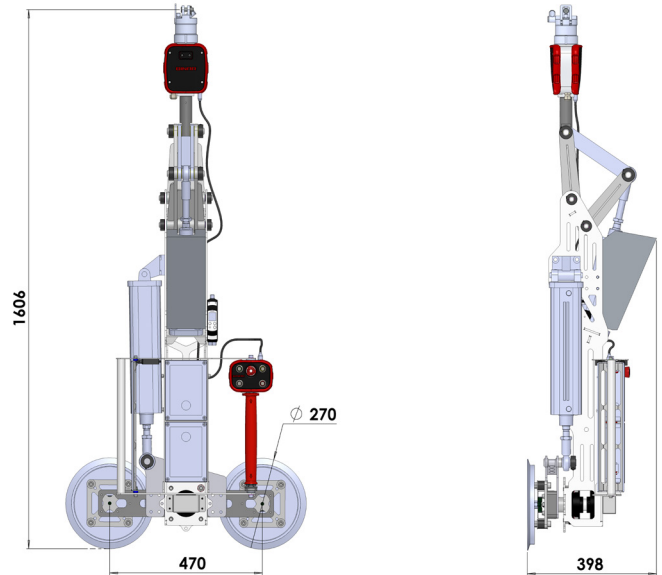
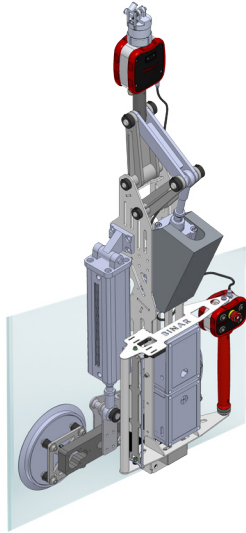

*Picture showing end effector with both manual and pneumatic rotation function.*

## TECHNICAL DATA

<b>Description</b>	<p>Equipped with fixed two round suction cups.</p> <p>The control handle provides a logic and simple interface for the operator for up and down movement as well push buttons for grip and release of the glass panels.</p> <p>The control box at the top provides setting of adjustable speed depending of the application.</p> <p>Manual or pneumatic rotation of glass panels.</p> <p>Pneumatic controlled centre of gravity (COG).</p> <p>Main direction of suction cups is to be defined. Degree of rotation is 0-180°.</p>
<b>Lifting capacity</b>	Glass panels : 80/150/240 kg depending on configuration of the suction cups.
<b>End effector weight</b>	55 kg Max, with manual rotation. 61 kg Max, with pneumatic rotation option.
<b>Air supply</b>	Clean dry air, pressure 6-8 bar.
<b>Safety</b>	<p>2 suction cups with a safety factor of 4.</p> <p>Both audio (buzzer) and visual (red lamp) indication when insufficient vacuum.</p> <p>Up movement is automatically restricted when too low vacuum is detected.</p> <p>Load is continuously supervised by the Quick-Lift and can only be released once end effector is landed on surface.</p>
<b>Options</b>	<p>Additional pneumatic cylinder built in for inclination (approx 10°).</p> <p>Vacuum tank (in case of insufficient vacuum).</p> <p>Pneumatically controlled rotation of glass panels.</p> <p>Degree of rotation 0-90°.</p>

Binar Handling AB disclaims responsibility for any errors or incomplete information in the published material and reserves the right to make changes

### Binar Handling AB

Hedekullevägen 24 • SE-461 38 TROLLHÄTTAN • Sweden  
 telephone: +46 (0)520 47 40 00 • e-mail: info.handling@binar.se  
 www.binarhandling.com

2021-07-05 EN 3.2

**BINAR**  
 Improving your productivity