

Quick-Lift Rail

QLR 125i

Intelligent lifting device which meets the highest standards of ergonomics, working environment, safety and efficiency.

Easy to use, thanks to outstanding responsiveness, regardless of load weight.

Unique integrated mechanical and electrical swivel simplifies use and minimizes maintenance.

The best auto balance available regardless of load weight.

High reliability and low power consumption results in superior cost efficiency.

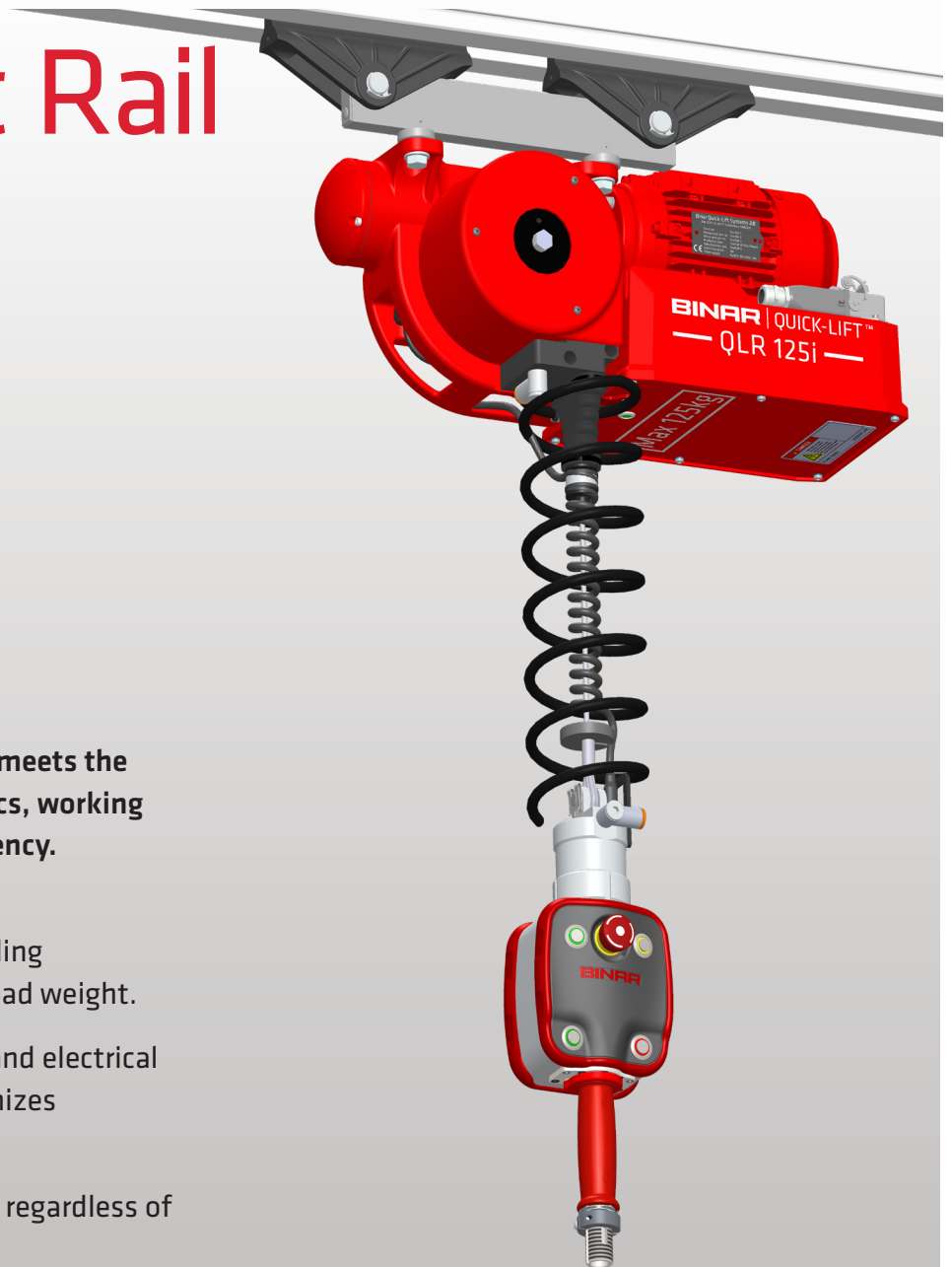

Quick-Lift Rail

QLR 125i

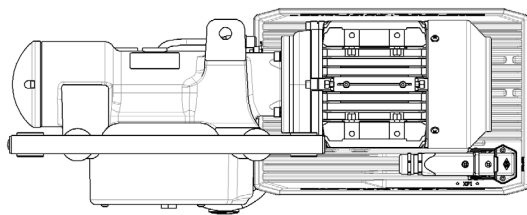
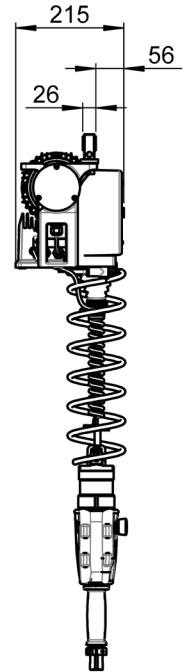
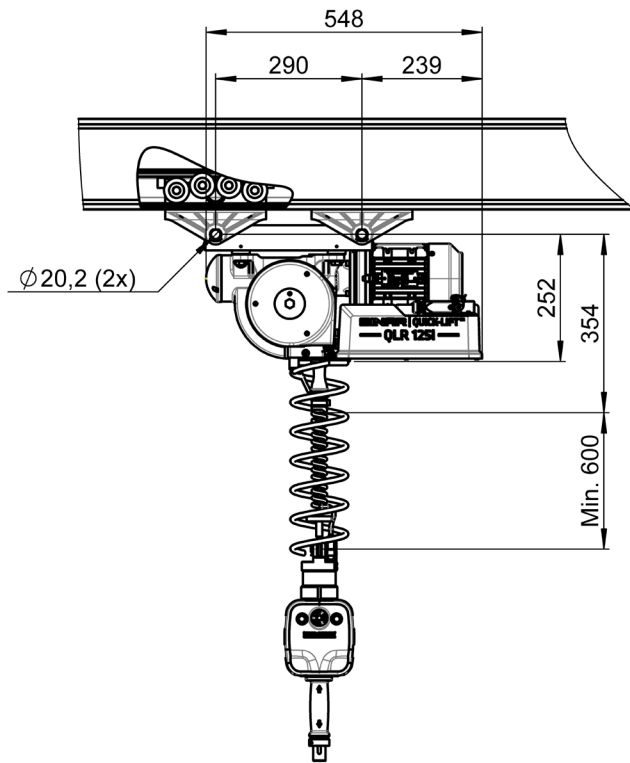

TECHNICAL DATA QLR 125i

Lifting capacity	Max 125 kg
Stroke length	2,7 meter
Lift motor	Stepless servo-controlled asynchronous motor
Weight	25 kg
Power supply	230V, 50-60 Hz, 1-phase with ground protection, 10A
Attachment	The QLR 125i can be mounted in the most types of rail systems. Existing rail systems can often be used.
Manoeuvring	<p>Manoeuvring is done by using a patented control handle or balancing mode. Both options sense the operator's hand/arm movement and give a very exact and smooth speed control.</p> <p>Only a small force is needed to engage the up/down motion. When the operator let go of the handle, the up/down motion is immediately stopped.</p>
End effector	End effectors are designed to fit customer's need. Intelligent I/O signals are available for optimum functionality.
Options	<p>Pneumatic brake. Three position brake system activated via a manual push button on the control handle.</p> <p>Pneumatic Stop-and-go brake. Three position laser actuated brake system.</p>

Binar Handling AB disclaims responsibility for any errors or incomplete information in the published material and reserves the right to make changes

Binar Handling AB

Hedekullevägen 24 • SE-461 38 TROLLHÄTTAN • Sweden
 telephone: +46 (0)520 47 40 00 • e-mail: info.handling@binar.se
 www.binarhandling.com

2021-01-28 EN 3.1

BINAR
 Improving your productivity